

# CONAIR® HOSPITALITY

2018 Product Catalog



## what's new

*Extended-stay travelers want to feel at home, and STAY by Cuisinart™ was designed to let them. These full-size countertop essentials, designed exclusively for the extended stay market, feature simple, user-friendly controls.*

*All travelers will appreciate the new Luna by Conair™ (WCR450) – a unique, new addition to the Conair® Hospitality line. Bluetooth® compatible with speakers to let guests listen to their own music. Two AC outlets on one side, two USB charging ports on the other.*

*Conair® Hospitality continues to expand across all categories. Four more alarm clocks, as well as additions to the personal care lines, will let your guests experience a truly superior level of comfort and convenience.*

# STAY BY Cuisinart™



**stay by cuisinart™**

PAGE **30**



**luna** by CONAIR  
alarm clock

PAGE **16**



**contents**

<i>hair dryers</i>	6
<i>coffeemakers/kettles</i>	12
<i>alarm clocks</i>	16
<i>irons/steamer</i>	20
<i>mirrors</i>	24
<i>scales</i>	28
<i>extended stay</i>	30
<i>food service equipment</i>	36
<i>product specifications</i>	38



**alarm clocks** PAGE **17**



**steam and dry irons**



PAGE **22**



**lighted mirrors** PAGE **25**



# hair dryers





## **CONAIR® 1875 Watt Ionic Dryer**

575WH

- Ionic Technology for Shiny, Healthy-Looking, Manageable Hair
- Long-Life AC Motor
- Full Salon Size
- Upscale Metallic Black Finish
- Independent Heat (3) and Speed (2) Controls
- Cool Shot Button
- Removable Filter
- Concentrator Attachment
- Storage Bag Available (BAG-HOSP)

*See full specs for model 575WH on page 39.*



## **Infiniti PRO by Conair® 3Q 1875 Watt Ionic Dryer with Brushless Motor**

3QHW

- Ionic Technology for Shiny, Healthy-Looking, Manageable Hair
- Brushless Motor Provides Long Life and Reduced Drying Times
- Titanium Ceramic Technology
- Patent-Pending, Noise-Reduction Technology
- Full Salon Size
- Independent Heat (3) and Speed (2) Controls
- Cool Shot Button
- Removable Filter
- Concentrator Attachment
- Storage Bag Available (BAG-HOSP)

*See full specs for model 3QHW on page 39.*





# hair dryers

## CONAIR® 1875 Watt Soft Surface™ Dryer

294WH

- Ionic Technology for Shiny, Healthy-Looking, Manageable Hair
- Long-Life AC Motor
- Full Salon Size
- Soft-Touch Finish Resists Fingerprints
- Stylish Rose Gold Accents
- Independent Heat (3) and Speed (2) Controls
- Cool Shot Button
- Removable Filter
- Concentrator Attachment
- Storage Bag Available (BAG-HOSP)

See full specs for model 294WH on page 39.



## CONAIR® 1875 Watt Ionic Dryer

425WWH

- Ionic Technology for Shiny, Healthy-Looking, Manageable Hair
- Independent Heat (3) and Speed (2) Controls
- Cool Shot Button
- Removable Filter
- Concentrator Attachment
- Storage Bag Available (BAG-HOSP)

See full specs for model 425WWH on page 39.



## CONAIR® 1875 Watt Ionic Dryer

425BKWH

- Ionic Technology for Shiny, Healthy-Looking, Manageable Hair
- Independent Heat (3) and Speed (2) Controls
- Cool Shot Button
- Removable Filter
- Concentrator Attachment
- Storage Bag Available (BAG-HOSP)

See full specs for model 425BKWH on page 39.







**CONAIR®  
1875 Watt Dryer  
with Ionic Conditioning**

229WWH

- Ionic Conditioning Helps Fight Frizz and Brings Out Natural Shine
- 2 Heat/Speed Settings
- Cool Shot Button
- Concentrator Attachment
- Storage Bag Available (BAG-HOSP)

*See full specs for model 229WWH on page 39.*



**CONAIR®  
1875 Watt Dryer  
with Ionic Conditioning**

229BKWH

- Ionic Conditioning Helps Fight Frizz and Brings Out Natural Shine
- 2 Heat/Speed Settings
- Cool Shot Button
- Concentrator Attachment
- Storage Bag Available (BAG-HOSP)

*See full specs for model 229BKWH on page 39.*



**CONAIR®  
1875 Watt  
Brushed Metal Dryer**

141WRW

- Upscale, Brushed Metal Barrel
- Full Salon Size
- Cool-Touch Surface
- Independent Heat (3) and Speed (2) Controls
- Cool Shot Button
- Removable Filter
- Concentrator Attachment
- Storage Bag Available (BAG-HOSP)

*See full specs for model 141WRW on page 39.*



**CONAIR®  
1875 Watt  
Chrome Dryer**

070RACHNW

- Upscale, Polished Chrome Barrel
- 2 Heat/Speed Settings
- Cool Shot Button
- Removable Filter
- Storage Bag Available (BAG-HOSP)

*See full specs for model 070RACHNW on page 40.*



# hair dryers

## CONAIR® 1875 Watt Ionic Cord-Keeper® Dryer

169CHIW

- Ionic Technology for Shiny, Healthy-Looking, Manageable Hair
- Polished Chrome Barrel
- Retractable Power Cord Helps Provide a Neat Presentation
- Folding Handle for Easy Storage
- 2 Heat/Speed Settings
- Cool Shot Button
- Storage Bag Available (BAG-HOSP)

See full specs for model 169CHIW on page 40.



## CONAIR® 1875 Watt Ionic Cord-Keeper® Dryer

169WIW

- Ionic Technology for Shiny, Healthy-Looking, Manageable Hair
- Retractable Power Cord Helps Provide a Neat Presentation
- Folding Handle for Easy Storage
- 2 Heat/Speed Settings
- Cool Shot Button
- Storage Bag Available (BAG-HOSP)

See full specs for model 169WIW on page 40.



## CONAIR® 1875 Watt Ionic Cord-Keeper® Dryer

169BIW

- Ionic Technology for Shiny, Healthy-Looking, Manageable Hair
- Retractable Power Cord Helps Provide a Neat Presentation
- Folding Handle for Easy Storage
- 2 Heat/Speed Settings
- Cool Shot Button
- Storage Bag Available (BAG-HOSP)

See full specs for model 169BIW on page 40.



## CONAIR® 1875 Watt Soft Surface™ Dryer

152B

- Soft-Touch Finish Resists Fingerprints
- Compact Size for Easy Storage
- 2 Heat/Speed Settings
- Cool Shot Button
- Hinged Air Filter for Easy Cleaning
- Storage Bag Available (BAG-HOSP)

See full specs for model 152B on page 41.





**CONAIR®  
1875 Watt Dryer**

247W – White  
247BW – Black

- Compact Size for Easy Storage
- 2 Heat/Speed Settings
- Cool Shot Button
- Concentrator Attachment
- Choose from White or Black
- Storage Bag Available (BAG-HOSP)

See full specs for models  
247W and 247BW on page 41.



**CONAIR®  
1600 Watt Dryer**

047W – White  
047BW – Black

- Compact Size for Easy Storage
- 2 Heat/Speed Settings
- Cool Shot Button
- Concentrator Attachment
- Choose from White or Black
- Storage Bag Available (BAG-HOSP)

See full specs for models  
047W and 047BW on page 41.

**CONAIR®  
1600 Watt  
Wall-Mount Dryer**

134W  
136W – Direct Wire Version

- LED Nightlight
- Auto Shutoff When Handset Is Placed in Wall Mount
- 2 Heat/Speed Settings
- Easy to Install – Mounting Hardware Included
- 6-Foot Coil Cord from Wall Mount to Handset
- Removable Air Filter

See full specs for models  
134W and 136W on page 41.



**CONAIR®  
1600 Watt  
Wall-Mount Dryer**

134BW

- LED Nightlight
- Auto Shutoff When Handset Is Placed in Wall Mount
- 2 Heat/Speed Settings
- Easy to Install – Mounting Hardware Included
- 6-Foot Coil Cord from Wall Mount to Handset
- Removable Air Filter

See full specs for model  
134BW on page 41.





# coffeemakers/kettles



## **CUISINART® 2-Cup Coffeemaker**

**WCM11**

- Brews One Cup (8 oz.) at a Time or Two Cups Simultaneously
- Uses Standard Single-Serve Coffee Pods  
*Cuisinart In-Room Coffee Program Available*
- Reusable, Dishwasher-Safe Brew Basket
- Automatic Shutoff When Brew Cycle Is Complete

*See full specs for model WCM11 on page 42.*



## CUISINART® 2-Cup Stainless Coffeemaker

*WCM11S*

- Upscale, Stainless Steel Finish
- Brews One Cup (8 oz.) at a Time or Two Cups Simultaneously
- Uses Standard Single-Serve Coffee Pods

### ***Cuisinart In-Room Coffee Program Available***

- Reusable, Dishwasher-Safe Brew Basket
- Automatic Shutoff When Brew Cycle Is Complete

*See full specs for model WCM11S on page 42.*



## CUISINART® 4-Cup Coffeemakers

*WCM04B – Glass Carafe*

*WCM08B – Brushed Stainless Carafe*

- Compact Design
- Brews Up to Four Cups (20 oz.)
- Uses Standard 4-Cup Coffee Filter Packs

### ***Cuisinart In-Room Coffee Program Available***

- Brew Pause™ Feature for Mid-Cycle Pouring
- Keep-Warm Plate
- Automatic Shutoff
- Choose from Glass or Brushed Stainless Carafe

*See full specs for models WCM04B and WCM08B on pages 42 and 43.*





# coffeemakers/kettles



## **CUISINART® Compact QuickKettle®**

***CK-5WWH – White***

***CK-5BKWH – Black***

- 0.5-Liter Capacity
- Quickly and Quietly Boils Water in Minutes
- One-Touch Operation
- Auto Shutoff, Overheat and Boil-Dry Protection
- Cordless Convenience – Lightweight Kettle Lifts Off Base for Easy Filling and Serving
- Concealed Heating Element to Prevent Mineral Buildup

***See full specs for models CK-5WWH and CK-5BKWH on page 43.***



## CUISINART® 1-Cup Coffeemaker

*W1CM5*

- Brews One Cup (8 oz.) in Less Than 4 Minutes
- Uses Standard Single-Serve Coffee Pods  
**Cuisinart In-Room Coffee Program Available**
- Reusable, Dishwasher-Safe Brew Basket
- Automatic Shutoff When Brew Cycle Is Complete

*See full specs for model W1CM5 on page 43.*



## CUISINART® 1-Cup Stainless Coffeemaker

*W1CM5S*

- Upscale, Stainless Steel Finish
- Brews One Cup (8 oz.) in Less Than 4 Minutes
- Uses Standard Single-Serve Coffee Pods  
**Cuisinart In-Room Coffee Program Available**
- Reusable, Dishwasher-Safe Brew Basket
- Automatic Shutoff When Brew Cycle Is Complete

*See full specs for model W1CM5S on page 43.*



## **NEW** Luna by CONAIR™ Alarm Clock Charging Station w/Bluetooth® Wireless Technology

WCR450

- Two USB Charging Ports Share 3.0 Amps of Power for Charging Tablets and Smartphones
- Two AC Power Outlets Can Conveniently Charge Additional Devices
- Bluetooth® Enabled for Wireless Audio Streaming
- Single-Day Alarm
- Stylish Design and Finishes
- Large LCD Display Shows Day, Date, Time and Alarm Settings
- Seven Display Brightness Levels
- Automatically Adjusts for Daylight Savings Time
- Easy to Set and Operate
- Battery Backup (batteries not included)

*See full specs for model WCR450 on page 44.*



The Bluetooth® word, mark and logos are registered trademarks owned by the Bluetooth SIG, Inc., and any use of such marks by Conair Corporation is under license. Other trademarks and trade names are those of their respective owners.

## **NEW** CONAIR Time™ Digital Alarm Clock with Dual USB Charging Ports

WCL70S – Silver

WCL70BK – Black

- Two USB Charging Ports (3.0 amps of power) for Charging Tablets and Smartphones
- Single-Day Alarm
- AUX Cord for Playing Music from Personal Device
- 0.9-inch Blue Display with Brightness Control
- Digital FM Tuner
- Easy to Set and Operate
- Snooze and Sleep Functions
- Battery Backup (batteries not included)

See full specs for models WCL70S and WCL70BK on page 44.



## **NEW** CONAIR Time™ Sync Bluetooth® Alarm Clock with Dual USB Charging Ports

WCL75S – Silver

WCL75BK – Black

- Bluetooth® Enabled for Wireless Audio Streaming
- Two USB Charging Ports (3.0 amps of power) for Charging Tablets and Smartphones
- Single-Day Alarm
- 0.9-inch Blue Display with Brightness Control
- Digital FM Tuner
- Easy to Set and Operate
- AUX Cord
- Snooze and Sleep Functions
- Battery Backup (batteries not included)

See full specs for models WCL75S and WCL75BK on page 45.



# alarm clocks





## CONAIR™ Compact Alarm Clock Radio

WCR02

- Compact Size
- Easy-To-Read 0.6-inch Display with Alarm ON and AM/PM Indicators
- Single-Day Alarm Feature
- Snooze and Sleep Functions
- Digital FM Tuner
- Battery Backup (batteries not included)

See full specs for model WCR02 on page 45.



## CONAIR™ Alarm Clock Radio with USB Charging Port

WCR14

- 2.0 Amp USB Charging Port Will Effectively Charge Tablets, Smartphones and Other Devices
- Single-Day Alarm Feature
- Easy-To-Read 0.9-inch Display with Alarm ON/OFF and AM/PM Indicators
- AUX Jack for Playing Music from Personal Devices
- Snooze and Sleep Functions
- Digital FM Tuner
- Battery Backup (batteries not included)

See full specs for model WCR14 on page 45.



# irons/steamer



**CONAIR® Iron Storage Bag**  
*See page 23*





## CONAIR® Full-Feature Steam and Dry Cord-Keeper® Iron

WCI306R – White

WCI306RBK – Black

- Retractable Cord for Easy Storage and Neat Presentation
- Cord Access Window Allows for Easy Correction of Twisted Cord
- Anti-Drip Feature Helps to Eliminate Spills that Could Damage Guests' Garments
- Auto Shutoff – 30 Seconds Horizontal and 8 Minutes Vertical with Audible Tone and Easy Reset
- Sliding Water-Fill Cover
- Vertical and Burst of Steam
- Self-Cleaning Mode Helps to Remove Buildup and Extend Life
- Spray Button
- Choose from White or Black
- Storage Bag Available (BAG-IRON)

See full specs for models  
WCI306R and WCI306RBK on page 45.



## CONAIR® Full-Feature Steam and Dry Iron

WCI316 – White

WCI316BK – Black

- Anti-Drip Feature Helps to Eliminate Spills that Could Damage Guests' Garments
- Auto Shutoff – 30 Seconds Horizontal and 8 Minutes Vertical with Audible Tone and Easy Reset
- Sliding Water-Fill Cover
- Vertical and Burst of Steam
- Self-Cleaning Mode Helps to Remove Buildup and Extend Life
- Spray Button
- Storage Bag Available (BAG-IRON)

See full specs for models  
WCI316 and WCI316BK on page 46.







## **NEW** CONAIR® Compact Full Feature Steam and Dry Iron

WCI216 – White  
WCI216BK – Black

- Anti-Drip Feature Helps to Eliminate Spills that Could Damage Guests' Garments
- Auto Shutoff – 30 Seconds Horizontal and 8 Minutes Vertical with Audible Tone and Easy Reset
- Vertical and Burst of Steam
- Spray Button
- Storage Bag Available (BAG-IRON)

See full specs for models WCI216 and WCI216BK on pages 46 and 47.



## CONAIR® Compact Steam and Dry Iron

WCI205

- Compact Size for Easy Storage
- Auto Shutoff
- Sliding Water-Fill Cover
- See-Through Water Tank
- Adjustable Temperature Control
- Storage Bag Available (BAG-IRON)

See full specs for model WCI205 on page 47.



## CONAIR® Iron Storage Bag

*BAG-IRON*

- Fits All Conair® Hospitality Steam Irons
- Flame-Retardant Material
- Provides a Clean and Secure Storage Option
- Labeled for Easy Identification by Guests
- Protects the Steam Iron While Not in Use and Extends Life
- Sturdy Zipper Closure and Convenient Cord Storage

See full specs for model BAG-IRON on page 47.



## CONAIR® Handheld Steamer

*GS23RWH*

- Effective on All Types of Fabrics, Linens and Drapes
- Fast Heat-Up and 15-Minute Steam Time
- Energy-Saving Steam Pause
- Dual Heat Settings
- Steam Trigger with Continuous ON Option
- Easy-to-Fill, Removable Water Reservoir

See full specs for model GS23RWH on page 47.





**CONAIR® Two-Sided LED  
Lighted Vanity Mirror**

*BE119WH – Satin Nickel*





**NEW CONAIR® Two-Sided LED Lighted Vanity Mirror**

*BE119WH – Satin Nickel*  
*BE119CWH – Polished Chrome*

- Lifetime LED Lighting – Bulbs Never Have to be Replaced
- Standard and 5x Magnification
- 8.5-inch Diameter
- ON/OFF Rocker Switch
- Clear Power Cord
- Convenient Power Outlet on Base

*See full specs for models BE119WH and BE119CWH on page 47.*

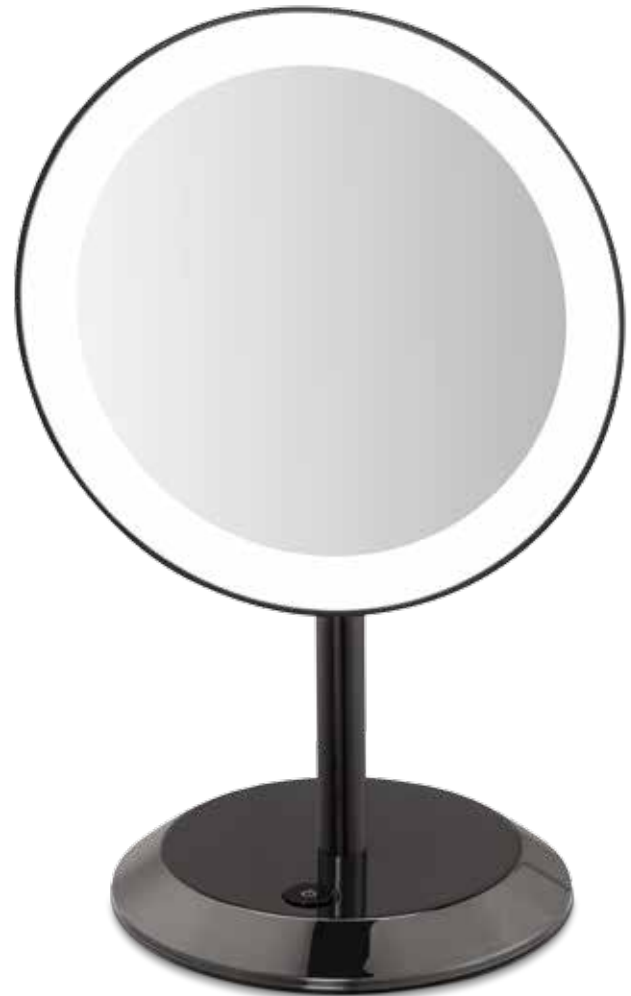

**CONAIR® LED Lighted Vanity Mirror**

*BE50LBCHW*

- Lifetime LED Lighting – Bulbs Never Have to be Replaced
- Sleek Black Chrome Finish with Slim Profile
- 5x Magnification
- 9-inch Diameter with 7-inch Viewing Area
- Adjustable Head Tilts Back and Forward
- ON/OFF Push Button on Base
- Clear Power Cord

*See full specs for model BE50LBCHW on page 48.*



## CONAIR® Two-Sided Lighted Vanity Mirror

BE103WH

- Satin Nickel Finish
- Standard and 5x Magnification
- 8.5-inch Diameter
- Circular Lighting with Four Settings
- Clear Power Cord
- Convenient Power Outlet on Base

See full specs for  
model BE103WH on page 48.



## CONAIR® Non-Lighted Vanity Mirror

41518W

- Polished Chrome Finish
- Two Sided
- Standard and 5x Magnification
- 8-inch Diameter

See full specs for model 41518W on page 48.

## NEW CONAIR® Two-Sided LED Lighted Wall-Mount Mirror

BE6BLEDCWH

- Polished Chrome Finish
- Lifetime LED Lighting – Bulbs Never Have to be Replaced
- Standard and 5x Magnification
- 8.5-inch Diameter
- Variable Lighting Options
- Clear Power Cord
- Easy to Mount – Hardware Included

See full specs for model BE6BLEDCWH on page 49.



## CONAIR® Non-Lighted Wall-Mount Mirror

41741W

- Polished Chrome Finish
- Two Sided
- Standard and 5x Magnification
- 8-inch Diameter
- Adjust to Any Angle for Easy Viewing
- Easy to Mount – Hardware Included

See full specs for model 41741W on page 49.



## CONAIR® Lighted Wall-Mount Mirror

BE8WMBW

- Polished Chrome Finish
- 5x Magnification
- 8-inch Diameter
- Extendable Arm and Clear Cord
- Easy to Mount – Hardware Included

See full specs for model BE8WMBW on page 49.





## **THINNER® Digital Glass Scale**

*MS-8140WH – Chrome*

- Polished Chrome Frame
- Tempered Safety Glass
- 4-Digit, 0.9-inch Digital Display
- 330 lb. Capacity

*See full specs for model MS-8140WH on page 49.*

**THINNER® Digital Glass Scale***MS-8012W*

- Polished Chrome Frame
- Tempered Safety Glass
- Reads in Both Lb. and Kg
- 4-Digit, 1.3-inch Digital Display
- 330 lb. Capacity

*See full specs for model MS-8012W on page 49.***THINNER® Speedometer Scale***MS-9560W*

- Matte Silver Finish
- Easy to Read, 4.5-inch Rotary Display
- Slip-Resistant Platform
- 350 lb. Capacity

*See full specs for model MS-9560W on page 49.*

# extended stay



---

**STAY**  
BY  
**Cuisinart™**

A value-driven, core assortment  
of kitchen electrics exclusively developed  
for extended-stay properties.

---





## **NEW** STAY by CUISINART™ Automatic Coffeemakers

WCM280W – White

WCM280BK – Black

WCM280S – Black/Stainless

- 12-Cup Glass Carafe
- Simple One-Button Operation
- Brew Pause™ Feature
- Auto Shutoff
- Uses Ground Coffee or Pre-Portioned Filter Packs

**Cuisinart In-Room Coffee Program Available**

See full specs for Stay by Cuisinart™ coffeemakers on page 50.

# extended stay

## NEW STAY by CUISINART™ Cordless Electric Kettles

WCK170W – White

WCK170S – Stainless

WCK170BK – Black

- 1.7-liter Capacity
- Power Switch with Blue Indicator Light
- Clear View Water Window
- Concealed Heating Element

See full specs for Stay by Cuisinart™ kettles on pages 50 and 51.



## NEW STAY by CUISINART™ Blenders

WCB120W – White

WCB120BK – Black

- BPA-Free, 48-oz. Jar
- Two Speeds with Pulse Feature
- Safety Interlocks

See full specs for Stay by Cuisinart™ blenders on page 51.



STAY  
BY  
Cuisinart™

## NEW STAY by CUISINART™ 2-Slice Toasters

WPT220W – White  
WPT220BK – Black  
WST240 – Stainless

- 1½-inch Toasting Slots
- 7 Browning Levels
- Slide-Out Crumb Tray

See full specs for Stay by Cuisinart™ 2-slice toasters on page 51.



## NEW STAY by CUISINART™ 4-Slice Toasters

WPT440W – White  
WPT440BK – Black  
WST480 – Stainless

- 1½-inch Toasting Slots
- 7 Browning Levels
- Slide-Out Crumb Tray

See full specs for Stay by Cuisinart™  
4-slice toasters on pages 51 and 52.





# extended stay

## **CUISINART® Dishwasher-Safe Anodized Cookware**

- Hard Anodized Exterior for Superior Durability
- Convenience of Dishwasher Cleanup
- Nonstick Cooking Surface
- Even Heat Distribution
- Oven Safe to 500° F
- Ergonomic Handles

*DSA22-20WH – 8-inch Skillet*

*DSA22-24WH – 10-inch Skillet*

*DSA19-14WH – 1-Quart Saucepan with Tempered Glass Cover*

*DSA19-18PWH – 2-Quart Pour Saucepan with Tempered Glass Cover*

*DSA66-22WH – 6-Quart Stockpot with Tempered Glass Cover*

*Full specs for Cuisinart® DSA cookware on pages 52 and 53.*





**CUISINART®**  
**SmartPower® Blender**  
*SPB-7CHW*

*See full specs for model  
SPB-7CHW on page 53.*



**CUISINART®**  
**12-Cup Programmable  
Coffeemaker**  
*DCC-1100W – White*



**CUISINART®**  
**12-Cup Programmable  
Coffeemaker**  
*DCC-1100BKW – Black*



**CUISINART®**  
**10-Cup Programmable  
Thermal Coffeemaker**  
*DCC-1150BKW – Black*

*See full specs for Cuisinart® coffeemakers on page 53.*



**CUISINART®**  
**2-Slice Compact Plastic Toaster**  
*CPT-122WH*



**CUISINART®**  
**2-Slice Compact Stainless Toaster**  
*CPT-320WH*



**CUISINART®**  
**2-Slice Classic Metal Toaster**  
*CPT-160WH*

*See full specs for Cuisinart® 2-slice toasters on page 54.*

# food service equipment



With 80 years as a leader in the foodservice industry, the Waring® Commercial Division of Conair® offers a full line of premium commercial products, perfect for all hospitality food and beverage programs.







*To learn more  
and browse  
our complete  
product  
selection, visit*

[www.waringcommercialproducts.com](http://www.waringcommercialproducts.com)

As a leader in professional kitchen equipment for the food service industry, Waring® Commercial's wide range of high-performance products is a great choice for the hospitality market. From toasters and waffle makers for breakfast buffets and concierge lounges to food processors, blenders and convection ovens for full- or limited-service hotel bars and kitchens, Waring® Commercial continues to set the standard for industry excellence.

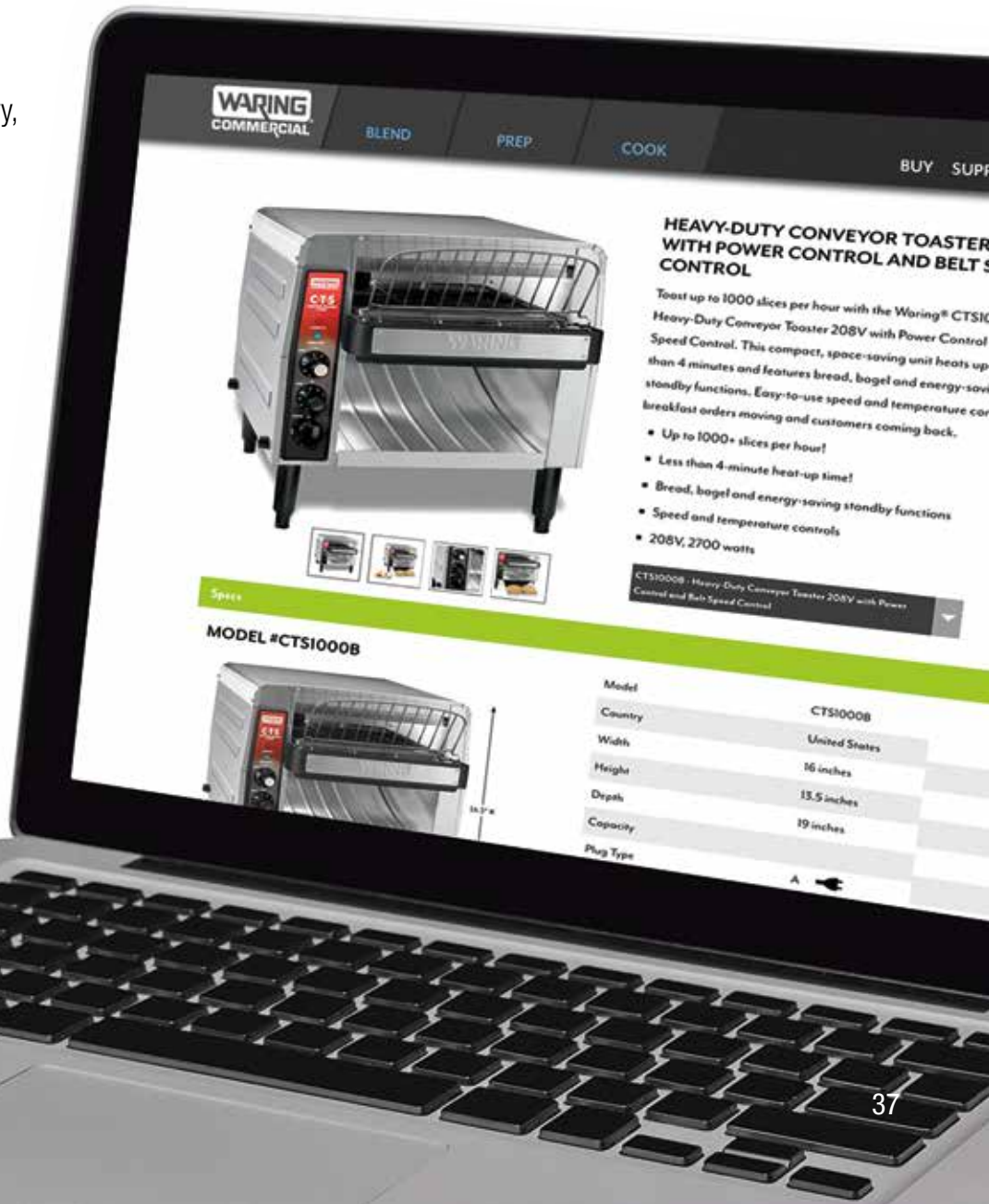

# product specifications



# product specifications

## 575WH

Master Pack: 2

Case Dimensions:  
12.625" x 8.375" x 10.5"

Case Weight: 4.5 lbs.

Case Cube: 0.642 cu.ft.

Product UPC:  
040072074493

Product MBC:  
10040072074490



## 425WWH / 425BKWH

Master Pack: 4

Case Dimensions:  
16" x 12" x 10"

Case Weight: 7.4 lbs.

Case Cube: 1.11 cu.ft.

Product UPC:  
425WWH – 040072073564  
425BKWH – 040072073625

Product MBC:  
425WWH – 10040072073561  
425BKWH – 10040072073622



## 3QHW

Master Pack: 2

Case Dimensions:  
10.25" x 8.62" x 13.5"

Case Weight: 5.2 lbs.

Case Cube: 0.69 cu.ft.

Product UPC:  
040072039737

Product MBC:  
10040072039734



## 229WWH / 229BKWH

Master Pack: 4

Case Dimensions:  
15" x 10.125" x 9.625"

Case Weight: 7.3 lbs.

Case Cube: 0.845 cu.ft.

Product UPC:  
229WWH – 040072073618  
229BKWH – 040072073380

Product MBC:  
229WWH – 10040072073615  
229BKWH – 10040072073387



## 294WH

Master Pack: 4

Case Dimensions:  
15.625" x 12.5" x 10.75"

Case Weight: 10 lbs.

Case Cube: 1.21 cu.ft.

Product UPC:  
040072073038

Product MBC:  
10040072073035



## 141WRW

Master Pack: 4

Case Dimensions:  
16.25" x 9.75" x 12"

Case Weight: 9.2 lbs.

Case Cube: 1.1 cu.ft.

Product UPC:  
040072004858

Product MBC:  
10040072004855





# product specifications



## 070RACHNW

Master Pack: 4

Case Dimensions:  
15.75" x 10" x 10.875"

Case Weight: 7.2 lbs.

Case Cube: 0.99 cu.ft.

Product UPC:  
040072005008

Product MBC:  
10040072005005



## 169CHIW

Master Pack: 4

Case Dimensions:  
10.25" x 8.875" x 14"

Case Weight: 7.8 lbs.

Case Cube: 0.73 cu.ft.

Product UPC:  
040072010439

Product MBC:  
10040072010436



## 169WIW / 169BIW

Master Pack: 4

Case Dimensions:  
10.25" x 8.875" x 14"

Case Weight: 7.8 lbs.

Case Cube: 0.73 cu.ft.

Product UPC:  
169WIW – 040072014451  
169BIW – 040072014444

Product MBC:  
169WIW – 10040072014458  
169BIW – 10040072014441



# product specifications

## 152B

Master Pack: 4

Case Dimensions:  
15.75" x 9.625" x 9.5"

Case Weight: 5.95 lbs.

Case Cube: 0.83 cu.ft.

Product UPC:  
074108019776

Product MBC:  
10074108019773



## 134W / 136W

Master Pack: 4

Case Dimensions:  
11.5" x 9.5" x 13.5"

Case Weight: 10.2 lbs.

Case Cube: 0.85 cu.ft.

Product UPC:  
134W – 040072001697  
136W – 040072001772

Product MBC:  
134W – 10040072001694  
136W – 10040072001779



## 247W / 247BW

Master Pack: 4

Case Dimensions:  
13.75" x 10.25" x 8"

Case Weight: 5.5 lbs.

Case Cube: 0.65 cu.ft.

Product UPC:  
247W – 040072013409  
247BW – 040072013393

Product MBC:  
247W – 10040072013406  
247BW – 10040072013390



## 134BW

Master Pack: 4

Case Dimensions:  
11.5" x 9.5" x 13.5"

Case Weight: 10.2 lbs.

Case Cube: 0.85 cu.ft.

Product UPC:  
040072003738

Product MBC:  
10040072003735



## 047W / 047BW

Master Pack: 4

Case Dimensions:  
13.5" x 10" x 8.25"

Case Weight: 5.6 lbs.

Case Cube: 0.65 cu.ft.

Product UPC:  
047W – 040072014932  
047BW – 040072014949

Product MBC:  
047W – 10040072014939  
047BW – 10040072014946



## BAG-HOSP (DRYER STORAGE BAG)

Master Pack: 100

Case Dimensions:  
13.125" x 11.25" x 8.25"

Case Weight: 9.05 lbs.

Case Cube: 0.704 cu.ft.

Product UPC:  
040072010477

Product MBC:  
10040072010474



# product specifications



## WCM11

Master Pack: 6

Case Dimensions:  
22.75" x 17.5" x 11.5"

Case Weight: 18.5 lbs.

Case Cube: 2.611 cu.ft.

Product UPC:  
040072004629

Product MBC:  
10040072004626



Approved for  
Commercial Use



## WCM11S

Master Pack: 6

Case Dimensions:  
22.5" x 17.5" x 11.5"

Case Weight: 14.2 lbs.

Case Cube: 2.73 cu.ft.

Product UPC:  
040072010743

Product MBC:  
1040072010740



Approved for  
Commercial Use



## WCM04B

Master Pack: 4

Case Dimensions:  
18" x 14.25" x 12.25"

Case Weight: 16 lbs.

Case Cube: 1.82 cu.ft.

Product UPC:  
040072602696

Product MBC:  
10040072602693



Intertek  
Approved for  
Hospitality Use





# product specifications

## WCM08B

Master Pack: 4

Case Dimensions:  
18" x 14" x 12"

Case Weight: 16 lbs.

Case Cube: 1.75 cu.ft.

Product UPC:  
040072001260

Product MBC:  
10040072001267



Intertek  
Approved for  
Hospitality Use



## W1CM5

Master Pack: 6

Case Dimensions:  
21.625" x 14.375" x 10.625"

Case Weight: 13.375 lbs.

Case Cube: 1.911 cu.ft.

Product UPC:  
040072006289

Product MBC:  
10040072006286



Approved for  
Commercial Use



## CK-5WWH

Master Pack: 4

Case Dimensions:  
14.875" x 7.875" x 14.25"

Case Weight: 9.15 lbs.

Case Cube: 0.966 cu.ft.

Product UPC:  
040072072727

Product MBC:  
10040072072724



Intertek  
Approved for  
Hospitality Use



## W1CM5S

Master Pack: 6

Case Dimensions:  
22" x 15" x 11"

Case Weight: 14.5 lbs.

Case Cube: 2.1 cu.ft.

Product UPC:  
040072009952

Product MBC:  
10040072009959



Approved for  
Commercial Use



## CK-5BKWH

Master Pack: 4

Case Dimensions:  
15" x 7.875" x 14.375"

Case Weight: 8.95 lbs.

Case Cube: 0.982 cu.ft.

Product UPC:  
040072072710

Product MBC:  
10040072072717



Intertek  
Approved for  
Hospitality Use



# Cuisinart®

Need coffee or tea for your guest rooms?

Visit [www.cuisinartcoffee.com](http://www.cuisinartcoffee.com)

# product specifications



## WCR450

Master Pack: 6

Case Dimensions:  
17" x 8.625" x 11.25"

Case Weight: 15 lbs.

Case Cube: 0.955 cu.ft.

Product UPC:  
040072079702

Product MBC:  
10040072079709



## WCL70S

Master Pack: 4

Case Dimensions:  
12" x 11.75" x 9.625"

Case Weight: 7 lbs.

Case Cube: 0.785 cu.ft.

Product UPC:  
040072075650

Product MBC:  
10040072075657



## WCL70BK

Master Pack: 4

Case Dimensions:  
12" x 11.75" x 9.625"

Case Weight: 7 lbs.

Case Cube: 0.785 cu.ft.

Product UPC:  
040072075636

Product MBC:  
10040072075633



# product specifications

## WCL75S

Master Pack: 4

Case Dimensions:  
12" x 11.75" x 9.625"

Case Weight: 7 lbs.

Case Cube: 0.785 cu.ft.

Product UPC:  
040072075667

Product MBC:  
10040072075664



## WCL75BK

Master Pack: 4

Case Dimensions:  
12" x 11.75" x 9.625"

Case Weight: 7 lbs.

Case Cube: 0.785 cu.ft.

Product UPC:  
040072075643

Product MBC:  
10040072075640



## WCR02

Master Pack: 12

Case Dimensions:  
12.75" x 8.125" x 11.75"

Case Weight: 9.7 lbs.

Case Cube: 0.704 cu.ft.

Product UPC:  
040072025013

Product MBC:  
10040072025010



## WCR14

Master Pack: 8

Case Dimensions:  
15.25" x 10" x 8.375"

Case Weight: 10.6 lbs.

Case Cube: 0.739 cu.ft.

Product UPC:  
040072033001

Product MBC:  
10040072033008



## WCI306R

Master Pack: 6

Case Dimensions:  
16.625" x 13.375" x 12.375"

Case Weight: 20.25 lbs.

Case Cube: 1.592 cu.ft.

Product UPC:  
040072019357

Product MBC:  
10040072019354



## WCI306RBK

Master Pack: 6

Case Dimensions:  
16.625" x 13.375" x 12.375"

Case Weight: 20.20 lbs.

Case Cube: 1.592 cu.ft.

Product UPC:  
040072019340

Product MBC:  
10040072019347





# product specifications



## WCI316

Master Pack: 6

Case Dimensions:  
16.625" x 13.375" x 12.375"

Case Weight: 19.8 lbs.

Case Cube: 1.592 cu.ft.

Product UPC:  
040072025006

Product MBC:  
10040072025003



## WCI316BK

Master Pack: 6

Case Dimensions:  
16.625" x 13.375" x 12.375"

Case Weight: 19.8 lbs.

Case Cube: 1.592 cu.ft.

Product UPC:  
040072075827

Product MBC:  
10040072075824



## WCI216

Master Pack: 6

Case Dimensions:  
13.75" x 13.375" x 6"

Case Weight: 15 lbs.

Case Cube: 0.639 cu.ft.

Product UPC:  
040072079443

Product MBC:  
10040072079440

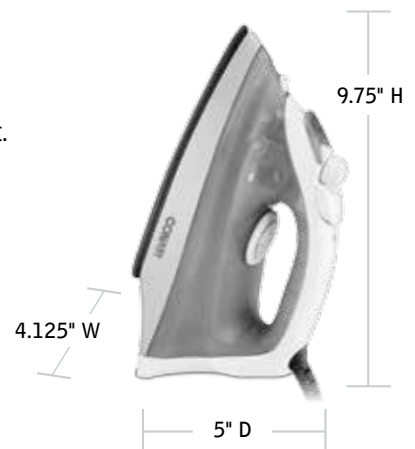

# product specifications

## WCI216BK

Master Pack: 6

Case Dimensions:  
13.75" x 13.375" x 6"

Case Weight: 15 lbs.

Case Cube: 0.639 cu.ft.

Product UPC:  
040072079450

Product MBC:  
10040072079457



## WCI205

Master Pack: 6

Case Dimensions:  
14.375" x 10.875" x 10.75"

Case Weight: 14.4 lbs.

Case Cube: 0.97 cu.ft.

Product UPC:  
040072001277

Product MBC:  
10040072001274



## BAG-IRON

Master Pack: 12

Case Dimensions:  
24.75" x 18.75" x 12.75"

Case Weight: 7.2 lbs.

Case Cube: 3.424 cu.ft.

Product UPC:  
040072072802

Product MBC:  
10040072072809



## GS23RWH

Master Pack: 2

Case Dimensions:  
12" x 8.375" x 14"

Case Weight: 6.8 lbs.

Case Cube: 0.815 cu.ft.

Product UPC:  
040072071829

Product MBC:  
10040072071826



## BE119WH

Master Pack: 4

Case Dimensions:  
20.25" x 15.75" x 17.5"

Case Weight: 17.3 lbs.

Case Cube: 3.23 cu.ft.

Product UPC:  
040072071539

Product MBC:  
10040072071536



## BE119CWH

Master Pack: 4

Case Dimensions:  
20.25" x 15.75" x 17.5"

Case Weight: 18.8 lbs.

Case Cube: 3.23 cu.ft.

Product UPC:  
040072079573

Product MBC:  
10040072079570

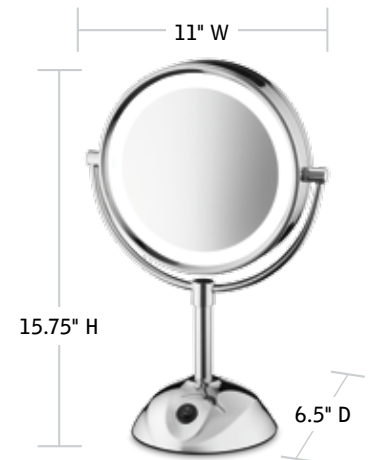

# product specifications



## BE50LBCHW

Master Pack: 4  
Case Dimensions:  
20.5" x 17.125" x 16.375"  
Case Weight: 16.2 lbs.  
Case Cube: 3.327 cu.ft.  
Product UPC:  
040072070518  
Product MBC:  
10040072070515

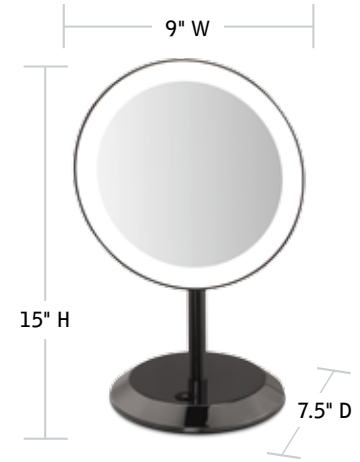

## BE103WH

Master Pack: 4  
Case Dimensions:  
20.25" x 15.75" x 17.5"  
Case Weight: 18.2 lbs.  
Case Cube: 3.23 cu.ft.  
Product UPC:  
040072071546  
Product MBC:  
10040072071543

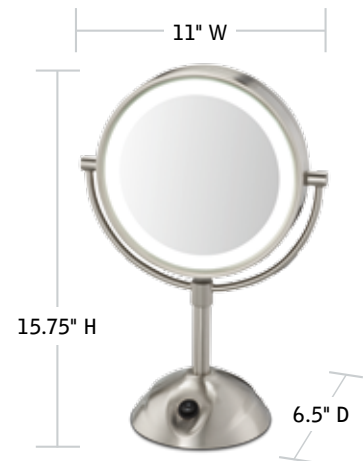

## 41518W

Master Pack: 3  
Case Dimensions:  
22.875" x 7.875" x 15.875"  
Case Weight: 11.45 lbs.  
Case Cube: 1.654 cu.ft.  
Product UPC:  
040072074509  
Product MBC:  
10040072074506





# product specifications

## BE6BLEDCWH

Master Pack: 4

Case Dimensions:  
19.875" x 13.375" x 18"

Case Weight: 23.05 lbs.

Case Cube: 2.77 cu.ft.

Product UPC:  
040072080074

Product MBC:  
20040072080078

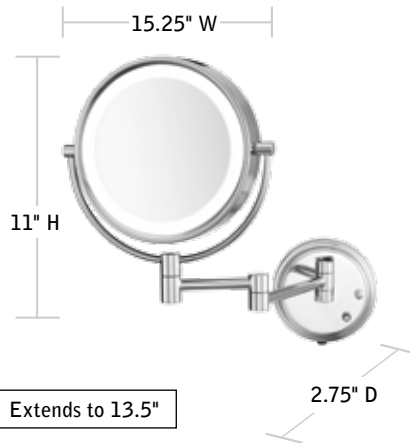

## MS-8140WH

Master Pack: 4

Case Dimensions:  
13.75" x 11" x 12.75"

Case Weight: 20.6 lbs.

Case Cube: 1.1 cu.ft.

Product UPC:  
040072004469

Product MBC:  
10040072004466

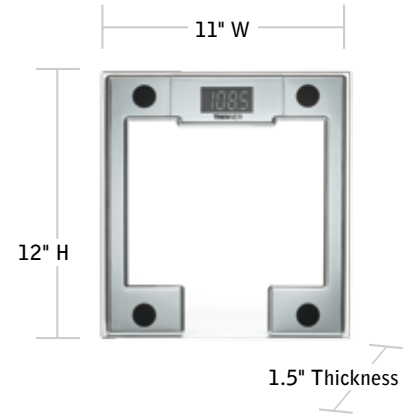

## 41741W

Master Pack: 6

Case Dimensions:  
13" x 11.25" x 14.25"

Case Weight: 15.4 lbs.

Case Cube: 1.206 cu.ft.

Product UPC:  
040072001857

Product MBC:  
10040072001854

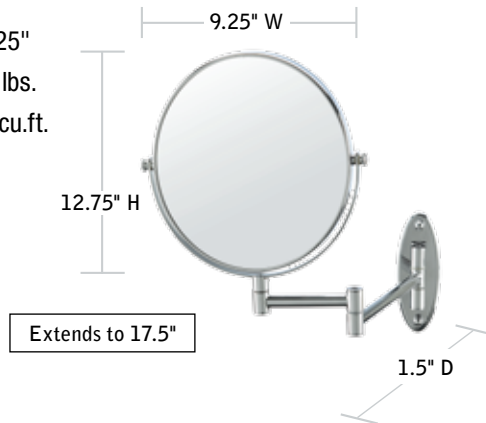

## MS-8012W

Master Pack: 4

Case Dimensions:  
13" x 11.75" x 13.75"

Case Weight: 21 lbs.

Case Cube: 1.22 cubic feet

Product UPC:  
040072005879

Product MBC:  
10040072005876



## BE8WMBW

Master Pack: 4

Case Dimensions:  
20" x 13.3" x 12.25"

Case Weight: 19.4 lbs.

Case Cube: 1.89 cu.ft.

Product UPC:  
040072002076

Product MBC:  
10040072002073

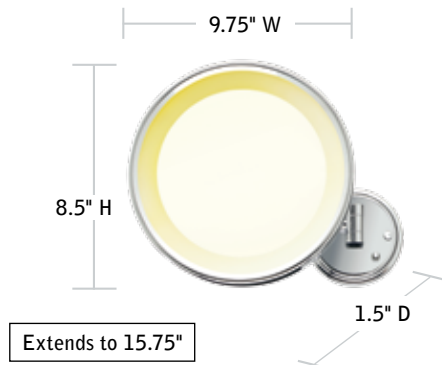

## MS-9560W

Master Pack: 4

Case Dimensions:  
15.875" x 13.125" x 13.75"

Case Weight: 21.9 lbs.

Case Cube: 1.612 cu.ft.

Product UPC:  
040072005428

Product MBC:  
10040072005425

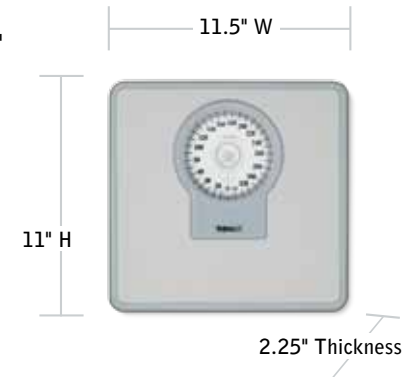

# product specifications



## WCM280W / WCM280BK

Master Pack: 2

Case Dimensions:  
22.625" x 10" x 16.875"

Case Weight: 15.2 lbs.

Case Cube: 2.209 cu.ft.

Product UPC:  
WCM280W – 040072076411  
WCM280BK – 040072076428

Product MBC:  
WCM280W – 10040072076418  
WCM280BK – 10040072076425



## WCM280S

Master Pack: 2

Case Dimensions:  
22.625" x 10" x 16.875"

Case Weight: 15.2 lbs.

Case Cube: 2.209 cu.ft.

Product UPC:  
040072076435

Product MBC:  
10040072076432



## WCK170W / WCK170BK

Master Pack: 6

Case Dimensions:  
25.125" x 8" x 20.875"

Case Weight: 15.8 lbs.

Case Cube: 2.428 cu.ft.

Product UPC:  
WCK170W – 040072076619  
WCK170BK – 040072076626

Product MBC:  
WCK170W – 10040072076616  
WCK170BK – 10040072076623



## WCK170S

Master Pack: 6

Case Dimensions:  
25" x 9" x 20"

Case Weight: 17.1 lbs.

Case Cube: 2.604 cu.ft.

Product UPC:  
040072076633

Product MBC:  
10040072076630



## WCB120W / WCB120BK

Master Pack: 4

Case Dimensions:  
18.25" x 15.25" x 15.125"

Case Weight: 22.2 lbs.

Case Cube: 2.436 cu.ft.

Product UPC:  
WCB120W – 040072076640  
WCB120BK – 040072076657

Product MBC:  
WCB120W – 10040072076647  
WCB120BK – 10040072076654



## WPT220W

Master Pack: 4

Case Dimensions:  
16" x 13" x 17.75"

Case Weight: 16 lbs.

Case Cube: 2.137 cu.ft.

Product UPC:  
040072076442

Product MBC:  
10040072076449

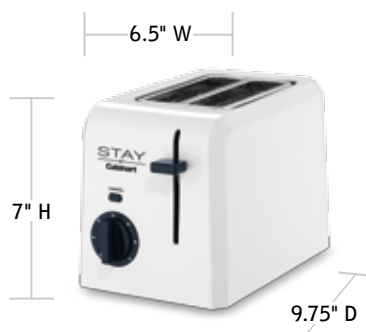

## WPT220BK

Master Pack: 4

Case Dimensions:  
16" x 13" x 17.75"

Case Weight: 16 lbs.

Case Cube: 2.137 cu.ft.

Product UPC:  
040072076459

Product MBC:  
10040072076456

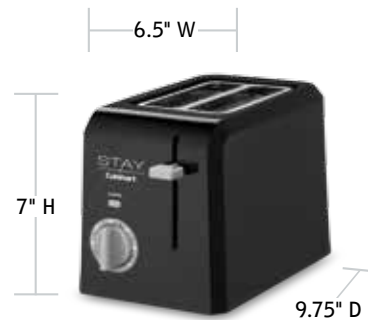

## WST240

Master Pack: 4

Case Dimensions:  
17" x 13.75" x 19.5"

Case Weight: 20.2 lbs.

Case Cube: 2.638 cu.ft.

Product UPC:  
040072076480

Product MBC:  
10040072076487

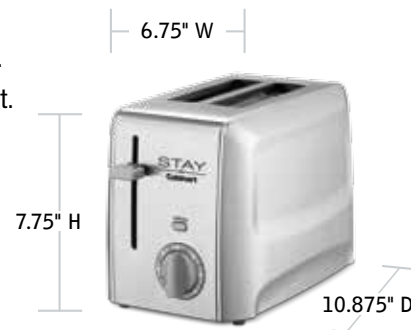

## WPT440W / WPT440BK

Master Pack: 2

Case Dimensions:  
12.625" x 12.25" x 17.875"

Case Weight: 12.1 lbs.

Case Cube: 1.616 cu.ft.

Product UPC:  
WPT440W – 040072076466  
WPT440BK – 040072076473

Product MBC:  
WPT440W – 10040072076463  
WPT440BK – 10040072076470





# product specifications



## WST480

Master Pack: 2

Case Dimensions:  
17" x 13.75" x 19.5"

Case Weight: 10.1 lbs.

Case Cube: 2.638 cu.ft.

Product UPC:  
040072076497

Product MBC:  
10040072076494

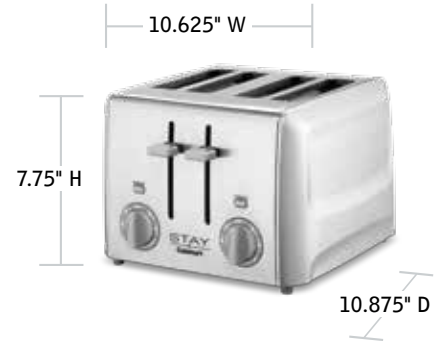

## DSA22-20WH

Master Pack: 4

Case Dimensions:  
16.375" x 9.75" x 11"

Case Weight: 9.4 lbs.

Case Cube: 1.016 cu.ft.

Product UPC:  
040072024306

Product MBC:  
10040072024303



## DSA22-24WH

Master Pack: 4

Case Dimensions:  
19.125" x 11.375" x 11.75"

Case Weight: 12 lbs.

Case Cube: 1.479 cu.ft.

Product UPC:  
040072024313

Product MBC:  
10040072024310



# product specifications

## DSA19-14WH

Master Pack: 4

Case Dimensions:  
17" x 14.875" x 9.875"

Case Weight: 11.4 lbs.

Case Cube: 1.445 cu.ft.

Product UPC:  
040072023446

Product MBC:  
10040072023443



## DSA19-18WH

Master Pack: 4

Case Dimensions:  
19.875" x 16.75" x 12.75"

Case Weight: 17.4 lbs.

Case Cube: 2.44 cu.ft.

Product UPC:  
040072024320

Product MBC:  
10040072024327



## DSA66-22WH

Master Pack: 4

Case Dimensions:  
23" x 15" x 15.375"

Case Weight: 24 lbs.

Case Cube: 3.069 cu.ft.

Product UPC:  
040072023439

Product MBC:  
10040072023436



## SPB-7CHW

Master Pack: 2

Case Dimensions:  
15.125" x 10.375" x 14"

Case Weight: 17 lbs.

Case Cube: 1.271 cu.ft.

Product UPC:  
086279104908

Product MBC:  
70086279104907



## DCC-1100W / DCC-1100BKW

Master Pack: 2

Case Dimensions:  
20.25" x 10.5" x 17"

Case Weight: 14 lbs.

Case Cube: 2.09 cu.ft.

Product UPC:  
DCC1100W - 040072019326  
DCC1100BKW - 040072019319

Product MBC:  
DCC1100W - 10040072019323  
DCC1100BKW - 10040072019316



## DCC-1150BKW

Master Pack: 2

Case Dimensions:  
20" x 10.25" x 17"

Case Weight: 15.2 lbs.

Case Cube: 2.01 cu.ft.

Product UPC:  
086279017376

Product MBC:  
50086279017371



# product specifications



## CPT-122WH

Master Pack: 4

Case Dimensions:  
16" x 12.75" x 17.75"

Case Weight: 16.65 lbs.

Case Cube: 2.09 cu.ft.

Product UPC:  
040072058349

Product MBC:  
10040072058346

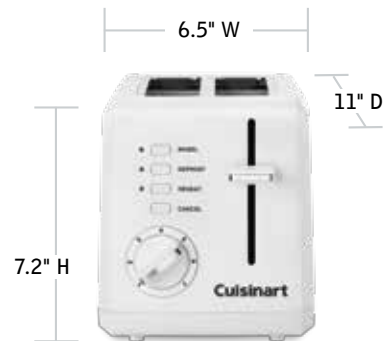

## CPT-160WH

Master Pack: 4

Case Dimensions:  
17" x 12.25" x 17"

Case Weight: 18.2 lbs.

Case Cube: 2.04 cu.ft.

Product UPC:  
086279003751

Product MBC:  
80086279003757

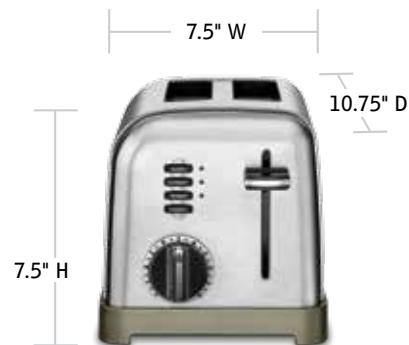

## CPT-320WH

Master Pack: 4

Case Dimensions:  
17.375" x 13" x 18.25"

Case Weight: 18.4 lbs.

Case Cube: 2.38 cu.ft.

Product UPC:  
040072047930

Product MBC:  
10040072047937

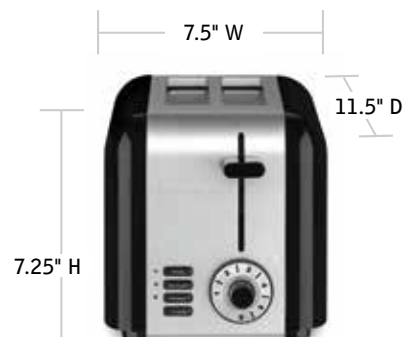



**For spec sheets, product updates and more, you can find us on the web at [www.conairhospitality.com](http://www.conairhospitality.com)**

The screenshot shows the Conair Hospitality website with a navigation bar including 'Home', 'Get Informed', and 'Quote List'. The main content area features a large image of a coffee maker, a blender, and a toaster, with the text 'INTRODUCING STAY BY Cuisinart'. Below this image are three promotional boxes: 'Stay by Cuisinart™' with a coffee maker icon, 'Iron Storage Bags' with a storage bag icon, and 'Get Informed' with a product catalog icon. The footer contains 'Terms and Conditions', 'Privacy Policy', and '©2017 Conair Hospitality'.

**CONAIR HOSPITALITY**

Home | Get Informed | Quote List

Search

PRODUCTS | EXTENDED STAY | ABOUT CONAIR HOSPITALITY | CUSTOMER CARE | COME SEE US

INTRODUCING  
**STAY**  
— BY —  
**Cuisinart**

**Stay by Cuisinart™**  
A value driven core assortment of kitchen electrics exclusively developed for extended-stay properties. Click for more info.

**Iron Storage Bags**  
Tired of messy coats? Conair's new BAG-IRON offers an attractive storage alternative. Click for more info.

**Get Informed**  
See How Conair Hospitality can help you give your guests all the comforts of home. Click here to receive the latest edition of the Conair Hospitality product offering.

Terms and Conditions | Privacy Policy | ©2017 Conair Hospitality

**CONAIR<sup>®</sup>**  
**HOSPITALITY**

© 2017 Conair Corporation  
314 Ella T. Grasso Avenue • Torrington, Connecticut 06790  
Tel. (800) 492-7464 • Fax. (860) 496-9017  
[www.conairhospitality.com](http://www.conairhospitality.com)  
email: [hospitality@conair.com](mailto:hospitality@conair.com)

17WH031325 PG-37159